

Econo-Treat[®] VBB

Aerated Sewage Treatment System

Model: VBB-C-3000-2 Advanced Secondary Treatment System

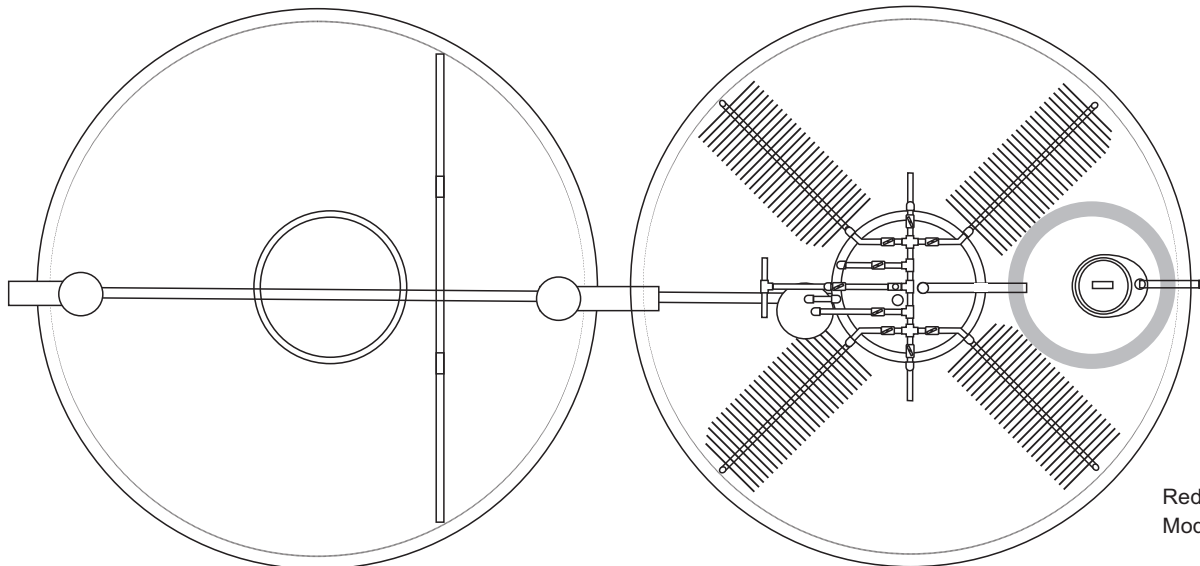
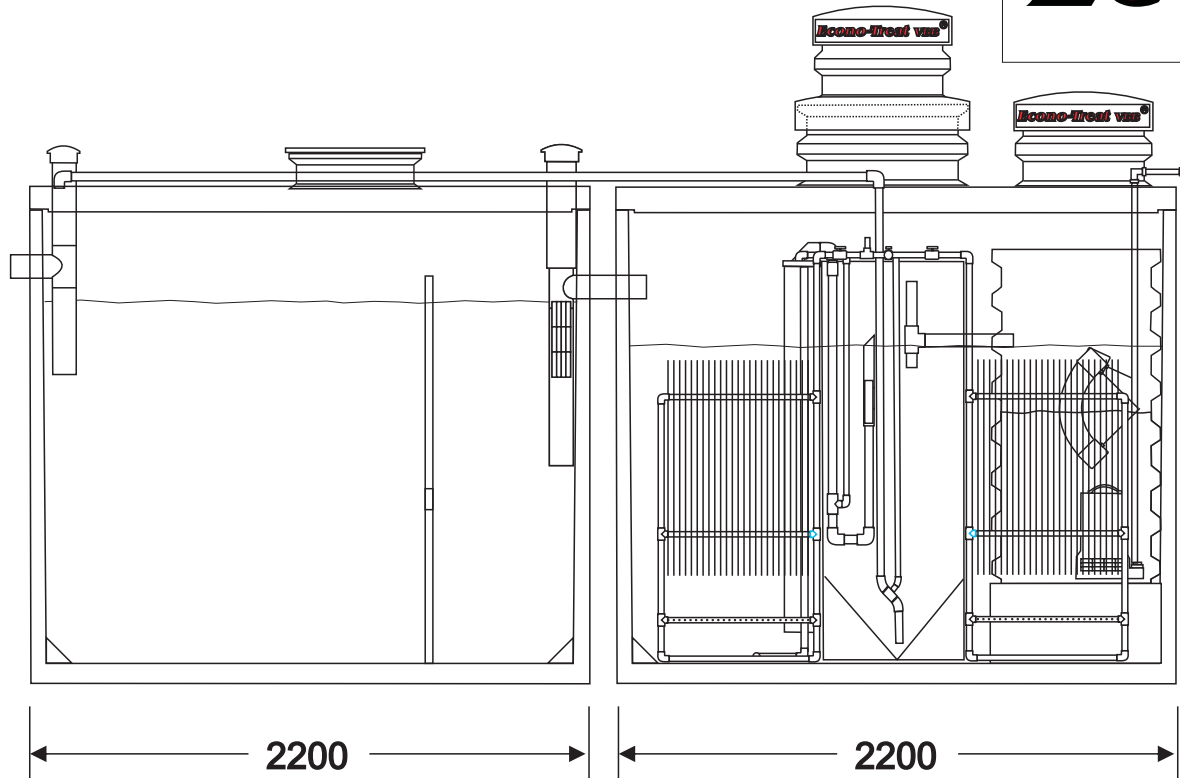

Manufacturer rated flow per day	3000LPD
Description of system process	Aerated submerged fixed film media (open and closed type). Intermittent operation (fine and very large bubble combo)
Air Blower Make/model kW	Nitto LA120 (121W)
Irrigation Pump	Easy Pump Deep 1000A 0.9KW 36M Head
Electrical controls & alarms	Air & high water alarms (Audible & visual) 10A circuit breaker Aeration controlled by time clock
Other components	Automatic sludge return to primary Air lift skimmer in clarifier
Irrigation drum	430L
Total emergency holding volume	3250L
All Tanks 2.2M Diameter	

Redrawn 5th August 2010
Modified 30th May 2011

VBB-C-3000-2.cdr



WAIPAPA TANKS
& Waste Treatment Systems Ltd

Ph 09 407 8323 Fax 09 407 8372

166 Waipapa Road, Kerikeri
sales@waipapatanks.co.nz