

# Septic Pump Station 5200L

Model: SPS-5200

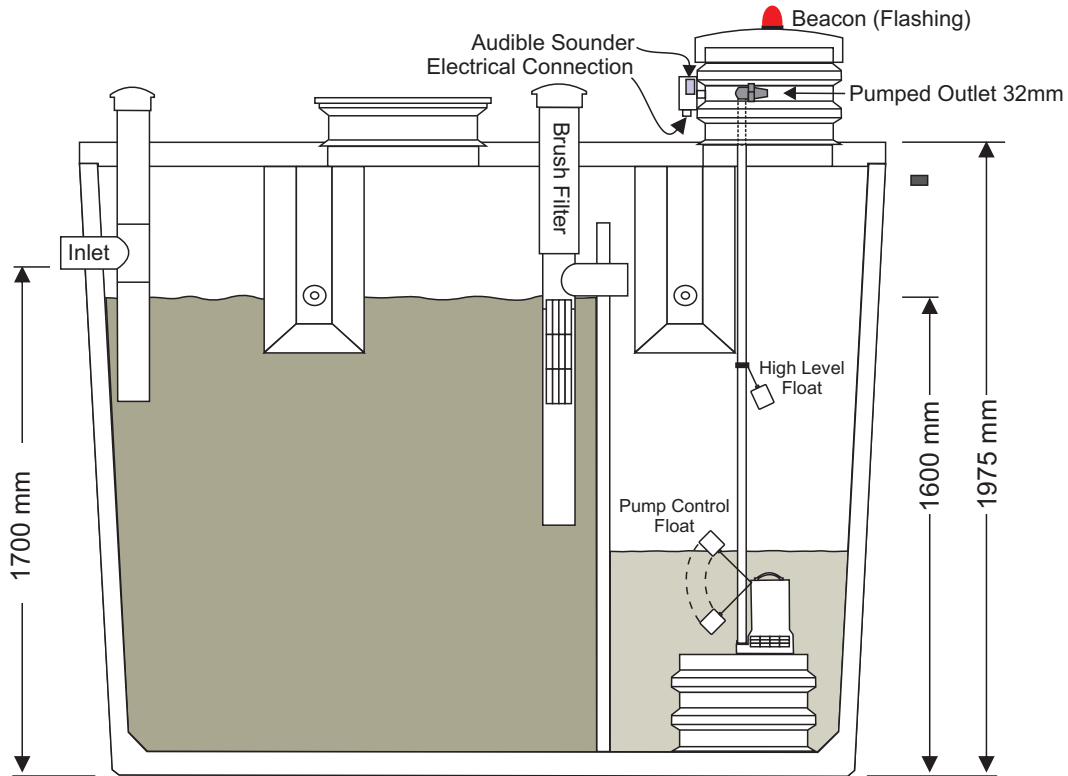
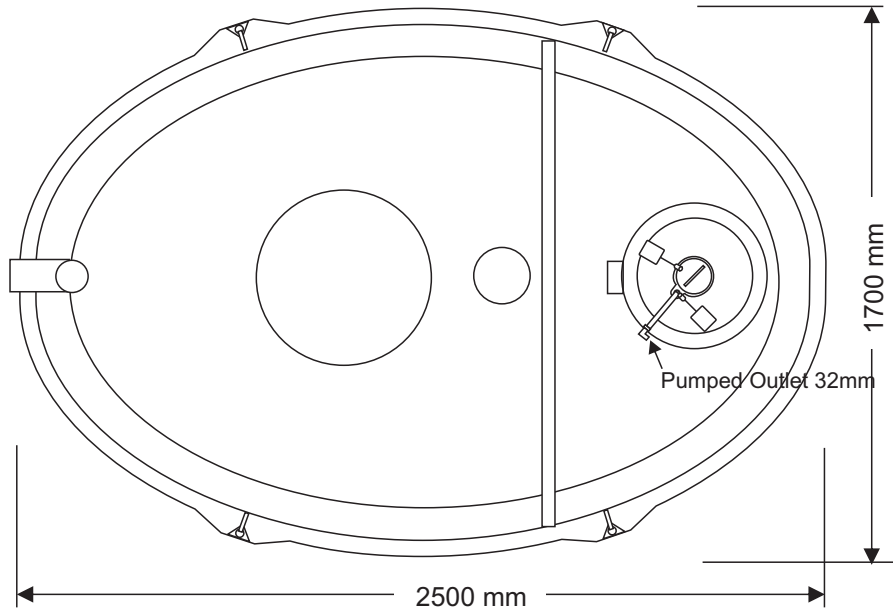

Description of system	Single Chamber Septic and Pumping Station combined
Total Volume	5200L
Filter Make/Model Location Size	Simtech Bristle Filter Outlet junction 100mm
Transfer Pump	Davey D15VA-3 Vortex Sump Pump Max head 7.5M Max Flow Rate 240 lpm 230vac, 150 watts
Electrical controls & alarms	High Level Alarm with Beacon and Audible Alarm. Pump Control build into Pump

Septic\_Pump\_Station\_5200L.cdr  
Drawn 28th March 2012



**WAIPAPA TANKS**  
& Waste Treatment Systems Ltd

Ph 09 407 8323 Fax 09 407 8372

166 Waipapa Road, Kerikeri  
sales@waipapatanks.co.nz